



Lever Block Range

Bullivants Lever Blocks are manufactured from the highest quality materials and equipped with the latest technology. This compact design includes innovative features to improve operator safety by making the lever block safer and easier to use ensuring a long service life.

Main Features:

- Overload Limiting devices also available to improve safety
- Lever blocks are fitted as standard twin pawl ratchets for 100% protection in the unlikely event of a spring or pawl failure
- Key internal components including gearing and sprockets are CNC machined for improved overall product reliability and longer life
- Load hooks with 'notched' safety latches increase service life of the latches and improve the safety of the lifting operation
- Stainless Steel ID plates and rivets suitable for underground applications
- Brake engages at minimum 3% of Working Load Limit
- High performance brake to ensure the integrity of the load under all conditions
- Designed in accordance with EN 13157 and AS 1418.2
- Complies with AS 1418.2

ZERO HARM Product Features:

- Improved design of load sprockets for safer operation
- Load hooks with cast 'notched' safety latches increase service life of the latches and improve the safety of the lifting operation
- Hi Visibility Colour contrast connecting points
- All Bullivants Lever Blocks are individually load tested in accordance with Australian Standards



Bullivants

Lever Block Range



Fitted with 100% engagement twin pawl ratchets in the unlikely event of a spring or pawl failure.



Key internal components including gearing and sprockets are CNC machined for improved overall product reliability and longer life.

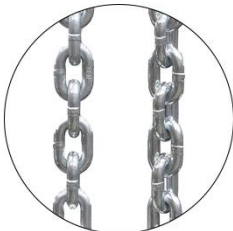

Improved load chain zinc plated alloy steel designed in accordance to EN818-7.



Load hooks with 'notched' safety latches as standard to increase service life of the latches and improve the safety of the lifting operation.

New design thrust bearing swivel hook for improved durability.



Stainless Steel ID plates and rivets suitable for underground applications.



QR code access to User Manual.

Bullivants

Lever Block Range



Specifications:

Bullivants Mfr No.		Rated Capacity (Kg)	Minimum load Kg*	Lifting height (m)	Test load (kN)	Hand force fully loaded (N)	No. of chain falls	Load Chain Grade 80 (mm)	Headroom (mm)	Dimensions (mm)						Net Weight (Kg)
Non-Overload Protection	Overload Protection									H	A	B	C	∅	D	
WHS-L-0025-010-BV	-	250	7.5	1.0	3.06	136	1	4 x 12	250	102	71	88	31	160	20	2.3
WHS-L-0050-015-BV	WHS-L-0050-015-BVOLP	500	15	1.5	6.13	256	1	5 x 15	330	143	90.5	118	31.5	245	22	5.5
-	WHS-L-0050-030-BVOLP	500	15	3.0	6.13	256	1	5 x 15	330	143	90.5	118	31.5	245	22	6.3
WHS-L-0080-015-BV	WHS-L-0080-015-BVOLP	800	24	1.5	9.80	250	1	6 x 18	365	157	94	140	37.5	245	26	7.5
WHS-L-0080-030-BV	WHS-L-0080-030-BVOLP	800	24	3.0	9.80	250	1	6 x 18	365	157	94	140	37.5	245	26	8.7
WHS-L-0160-015-BV	WHS-L-0160-015-BVOLP	1,600	48	1.5	19.60	373	1	6 x 18	400	178	104	145	42.5	325	29	9.6
WHS-L-0160-030-BV	WHS-L-0160-030-BVOLP	1,600	48	3.0	19.60	373	1	7 x 21	400	178	104	145	42.5	325	29	11.2
WHS-L-0320-015-BV	WHS-L-0320-015-BVOLP	3,200	96	1.5	39.20	416	1	10 x 30	520	206	118	199	50	405	39	20.0
WHS-L-0320-030-BV	WHS-L-0320-030-BVOLP	3,200	96	3.0	39.20	416	1	10 x 30	520	206	118	199	50	405	39	23.2
WHS-L-0630-015-BV	WHS-L-0630-015-BVOLP	6,300	189	1.5	77.18	420	2	10 x 30	595	206	118	230	65	405	46	30.0
WHS-L-0630-030-BV	WHS-L-0630-030-BVOLP	6,300	189	3.0	77.18	420	2	10 x 30	595	206	118	230	65	405	46	36.5
WHS-L-0900-015-BV	-	9,000	270	1.5	110.25	410	3	10 x 30	800	206	118	342	85	405	55	51.0

*Never attempt to lift a load below 3% of the Rated Capacity (Kg)

1300 LIFTING

info@bullivants.com
www.bullivants.com

Bullivants

Lever Block Range



Technical Drawings:

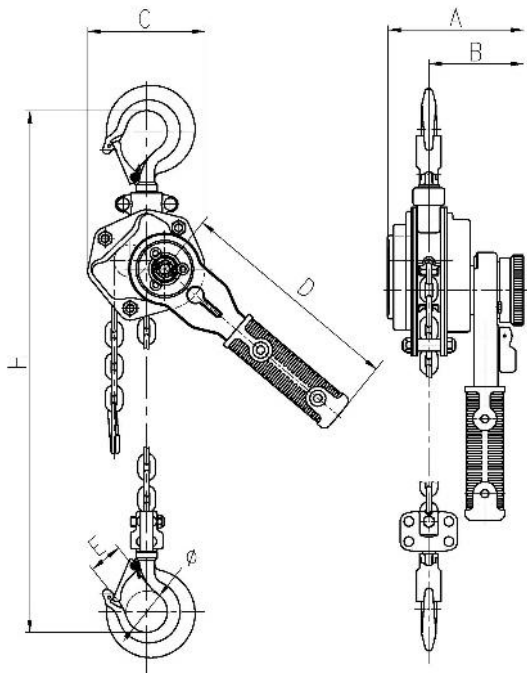

250kg

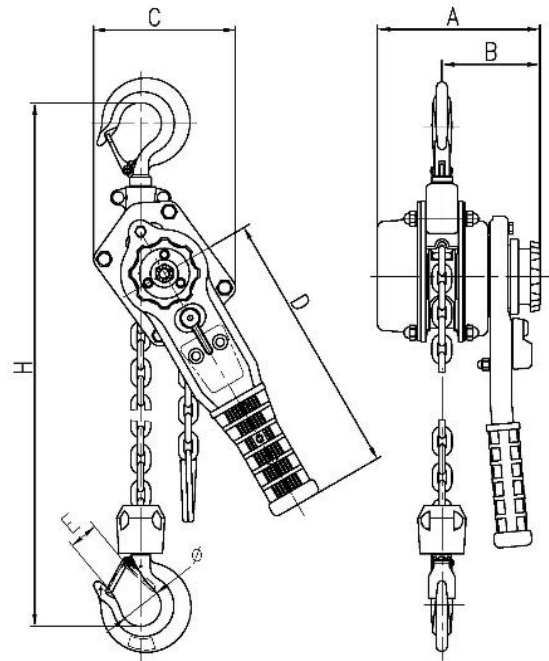

500kg – 3.2t

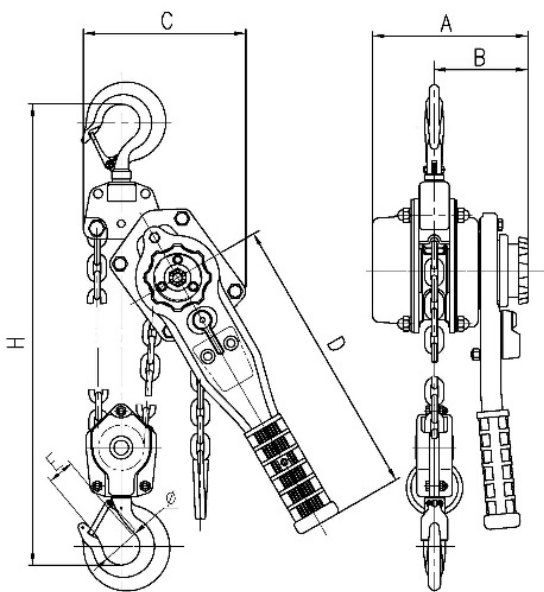

6.3t

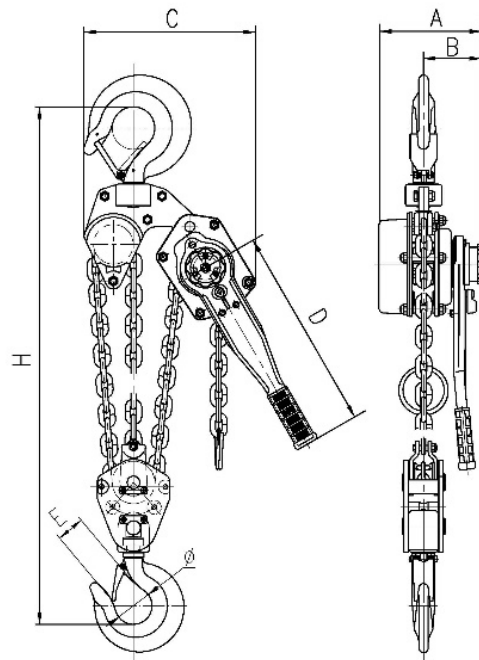

9t

Bullivants

Lever Block Range



Minimum Load Required for Brake to Engage:

Rated WLL Capacity	Minimum Load for automatic closing of the brake (Kg)
250	7.5
500	15
800	24
1,600	48
3,200	96
6,300	189
9,000	270

Latch Kits:

Suitable for WLL hooks	Description	BV Item Code
0.25t	LATCH KIT FOR 0.25T BV HOIST HOOK	WSHP-L-BV-LK-0025
0.5t	LATCH KIT FOR 0.5T BV & BVOLP HOIST HOOK	WCBP-BVOLP-LK-0050
0.8t	LATCH KIT FOR 0.8T BV & BVOLP HOIST HOOK	WHSP-L-BVOLP-LK-0080
1.6t	LATCH KIT FOR 1.6T BV & BVOLP HOIST HOOK	WHSP-L-BVOLP-LK-0160
3.2t	LATCH KIT FOR 3.2T BV & BVOLP HOIST HOOK	WHSP-L-BVOLP-LK-0320
6.3t	LATCH KIT FOR 6.3T BV & BVOLP HOIST HOOK	WHSP-L-BVOLP-LK-0630
9.0t	LATCH KIT FOR 9.0T & 10.0T BV HOIST HOOK	WCBP-BV-LK-1000

Cast Steel Latch Kit,
suitable for BV &
BVOLP Hoist Hooks



Demonstration of Overload Protection